

INSTALLATION AND OPERATION F27 TIME DELAY FLOW SWITCH

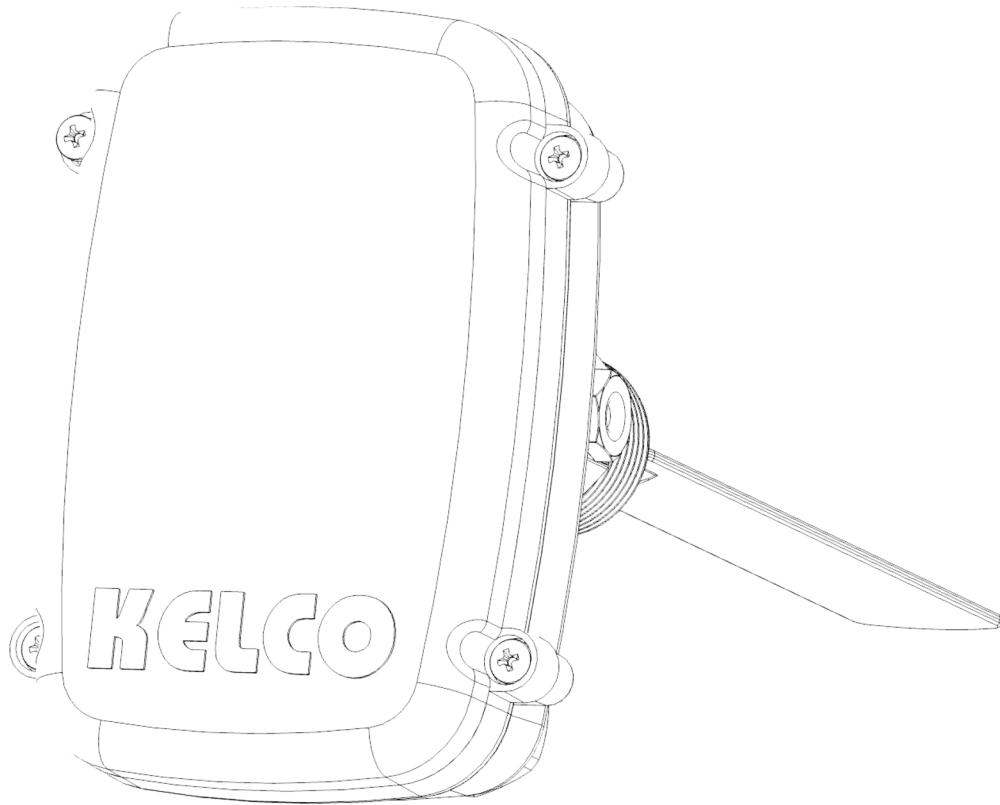

Link to Webpage

The F27 Time Delay Flow Switch requires both electrical and mechanical fitting. Installation or servicing of this flow switch should only be carried out by competent qualified personnel.



WARNING: NEVER CHANGE DIAL SETTINGS UNLESS THE F27 IS ISOLATED AND THE MAINS SUPPLY IS TURNED OFF



WARNING: WARRANTY IS VOID UNLESS THE CABLE GLANDS ARE PROPERLY ASSEMBLED AND SEALED AS PER THE INSTALLATION SHEET

INSTALLATION

A suitable location should be selected for the F27, preferably in the discharge pipework of the pump. The F27 should be installed in a location that is away from both vibration and heat, preferably out of direct exposure to the weather and above any flood level. Depending on model, the F27 has either a 1" BSP or 1" NPT process connection, therefore a suitably sized pipe tee or tapping saddle must be provided in the pipework. The socket should be located on the topside of a horizontal section of the discharge pipe with at least 5 diameters of straight pipe either side of it. Under no circumstances mount the F27 under the pipe or close to valves, tees, bends or any other object likely to cause turbulence in the flow.

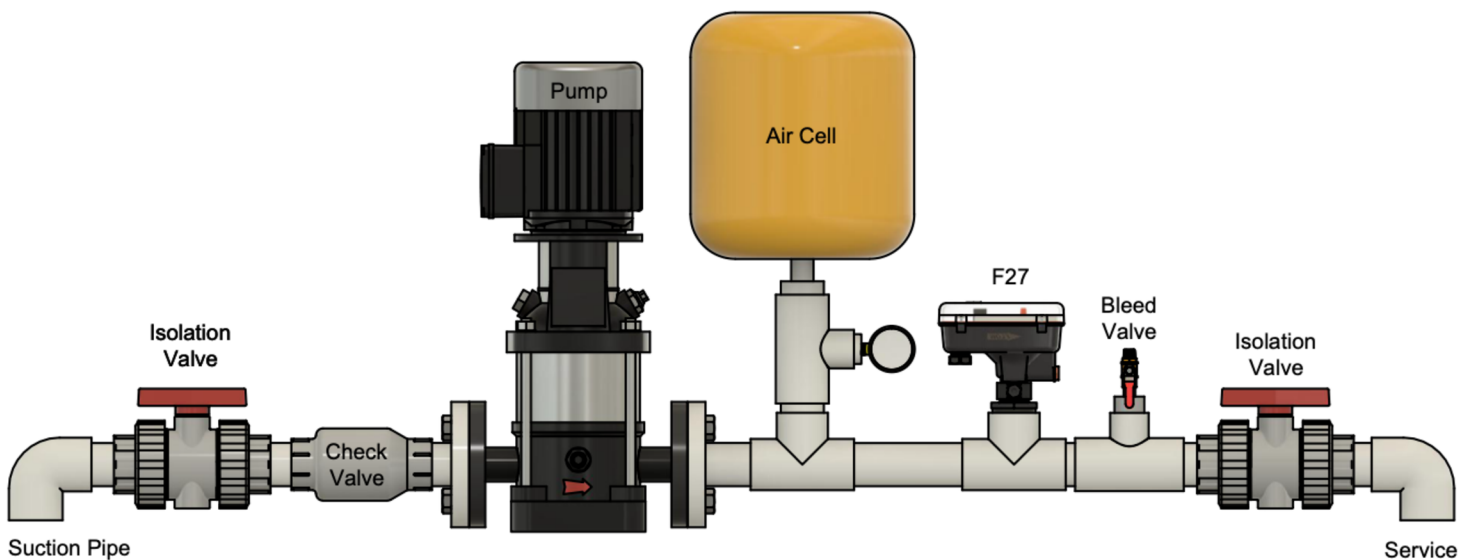

MOUNTING

The electrical head of the F27 can be removed from the paddle assembly if required. This is to allow easy installation or to allow the paddle assembly to be removed from the pipework without the need to disconnect wiring from the electrical head. To do this, simply unscrew and remove the Phillips head screw located below the electrical head. Once the screw has been completely removed pull the electrical head straight up and lift it off. To refit the electrical head locate it on the process connection and replace, re-fit and tighten the locking screw. We recommend isolation valves be fitted in both the suction and discharge pipes in all installations to allow servicing of the pump and the F27. We also recommend a bleed valve be included in the discharge pipe close to the pump and downstream of the controller for testing and setting up the system.

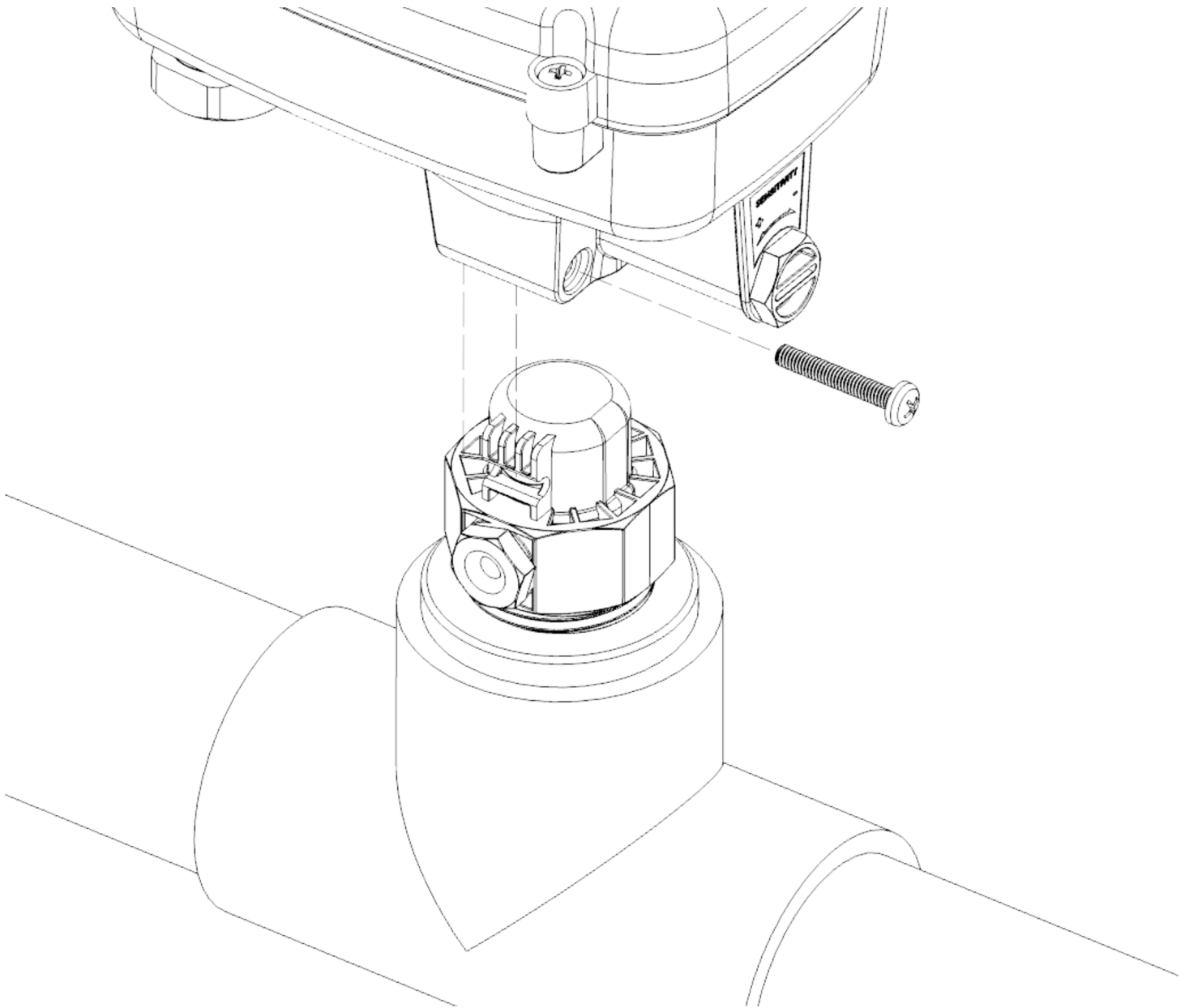

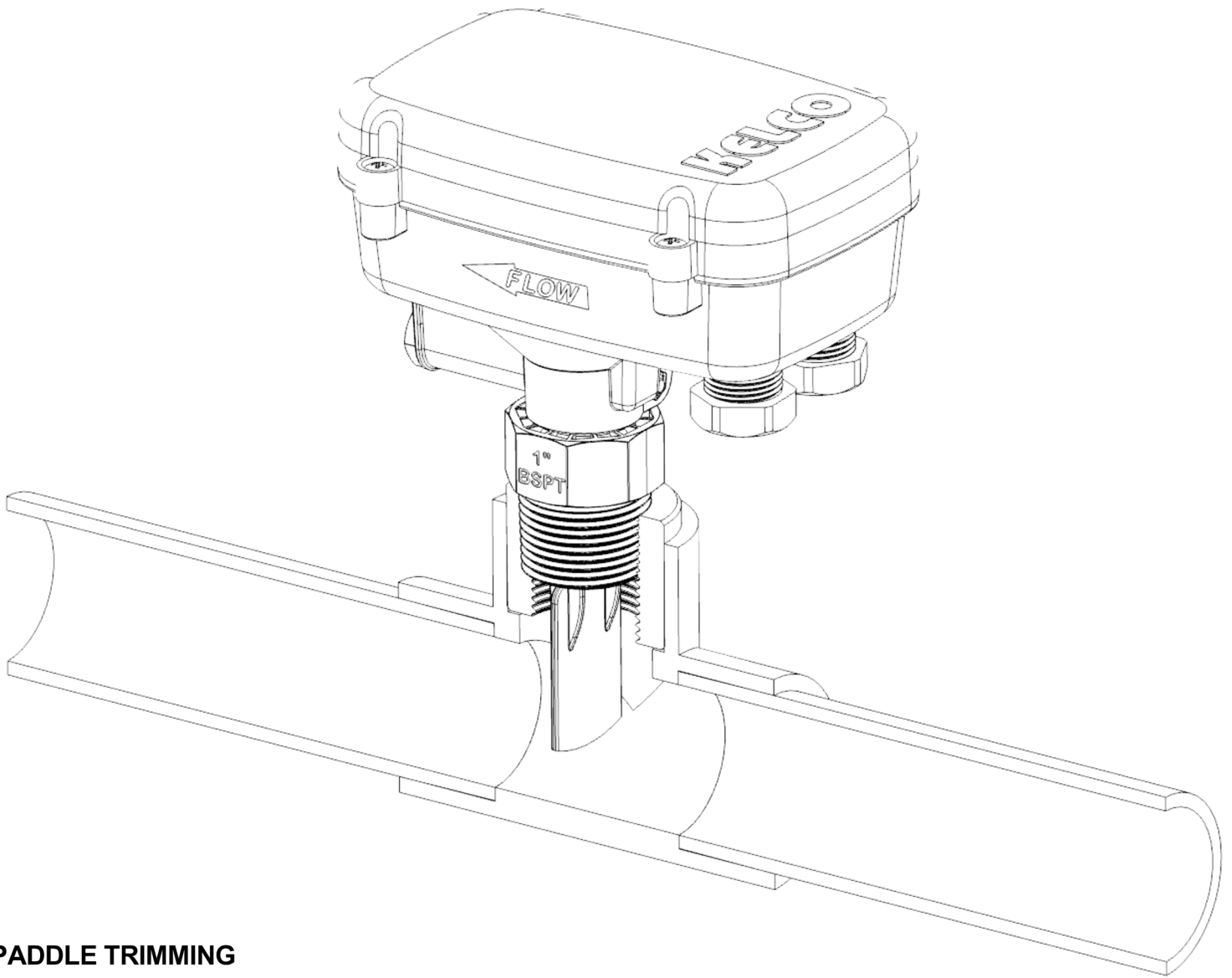

PADDLE TRIMMING

In most installations the paddle of the F27 will need to be trimmed to suit the specific pipe in which the switch is to be installed. The paddle of the flow switch needs a force of 10 to 20 grams acting on it from the flow in order to operate correctly. High velocity flow can generate high forces and damage or break the paddle. As a general guide the paddle should only extend to the centre line of the pipe, or slightly past the centre line. The paddle would not normally be left longer than this unless the flow velocity is very low. The paddle can be trimmed in both length and width if required. Cut the paddle of the switch using a hacksaw or tin snips so that when installed in the pipe the paddle clears the inside of the pipe at all points by at least 4mm.

Paddle length can be found using our online paddle trimming calculator:

www.kelco.com.au/paddle-trimming-calculator

Apply Teflon tape or a suitable thread sealant and screw the flow switch into the socket using the spanner flats provided. Do not twist the body of the F27 or use it to screw the switch into the socket, as to do so may damage the switch housing. When properly installed there should be a gap of at least 4mm between the top of the thread and the under edge of the spanner flats. Under no circumstances should the thread be allowed to bottom out in its socket as to do so places the thread in tension and may result in the pressure housing on the flow switch cracking under pressure. Ensure the flow direction arrow on the side of the F27 aligns with the direction of flow through the pipe. The F27 will not operate properly unless its paddle presents a flat face to the incoming flow.

SENSITIVITY ADJUSTMENT

Remove the plug and using a broad bladed screwdriver wind the adjusting screw anticlockwise to INCREASE the sensitivity (DECREASE the flow rate needed to actuate the paddle). As supplied the screw is wound fully in, set to its minimum sensitivity. The maximum sensitivity is reached with the screw wound out to a point where the red dust cover can still be refitted.

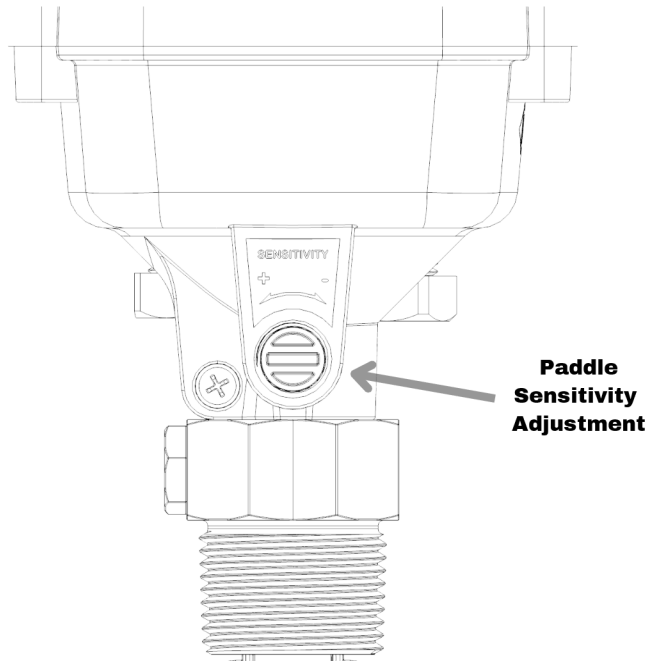

ELECTRICAL

The F27 requires a continuous stable electrical supply. In most installations it will also need an isolation switch to allow the system to be reset. The F27 is protected from over voltage by inbuilt varistors that will trip the control circuit breaker in the event of a voltage surge beyond the limits of the built in over volt protection.

DC Operation, using the LV and N terminals (Low Voltage DC operation)	
Minimum Voltage	19.5 Volts DC
Maximum Voltage	26 Volts DC
Current Draw	30mA with the output relay closed
AC operation, using the LV and N terminals (Low Voltage AC operation)	
Minimum Voltage	17 Volts AC
Maximum Voltage	26 Volts AC
Current Draw	80mA with the output relay closed
AC operation using the A and N terminals (50Hz Mains Voltage operation)	
Minimum Voltage	180 Volts AC
Maximum Voltage	270 Volts AC
Current Draw at 220VAC	240mA
Current Draw at 270VAC	270mA

CABLE GLANDS

The F27 is provided with two M20 cable glands. The cable glands are designed to accept cable from 7mm to 9mm diameter. The cable glands should be assembled as per the included diagram and the M20 gland nuts should be properly tightened to ensure the weather resistant integrity of the housing.

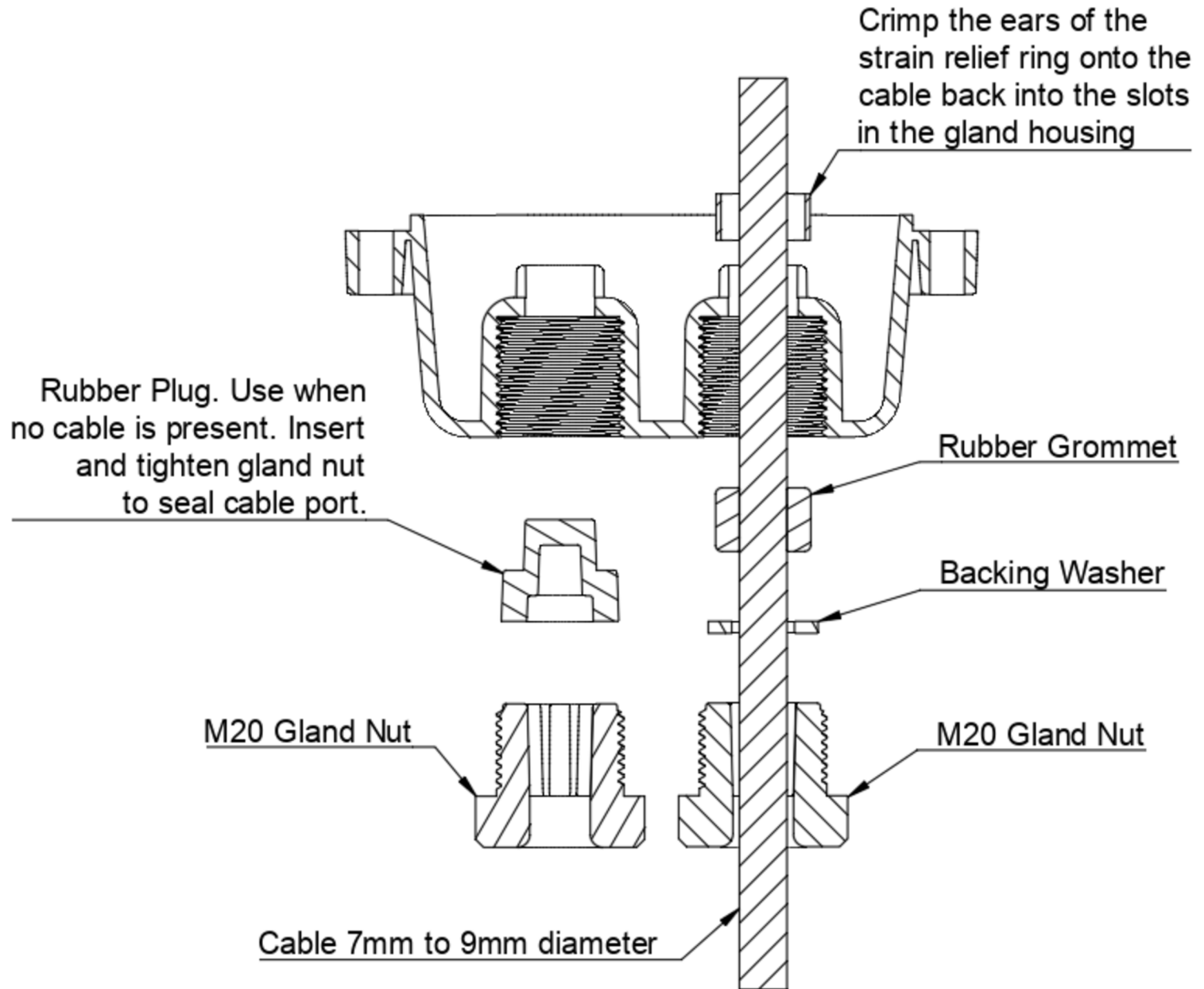

SUPPLY VOLTAGE

The F27 can be powered by connecting a 220/240VAC supply to its A (Active) and N (Neutral) terminals. It can also be powered from a 24VAC or 24VDC supply connected to its LV (Low Voltage) and N (Neutral) terminals. The F27 includes a builtin relay. The voltage free contacts of the relay are marked C (Common) and NO (Normally Open). The relay contacts act as a normally open switch and can be used in general purpose control circuit applications such as the control of relays and contractors with 24 or 240VAC coils. The maximum non-inductive load the relay contacts are rated for is 10A at 240VAC.

24 Volts AC / DC Supply

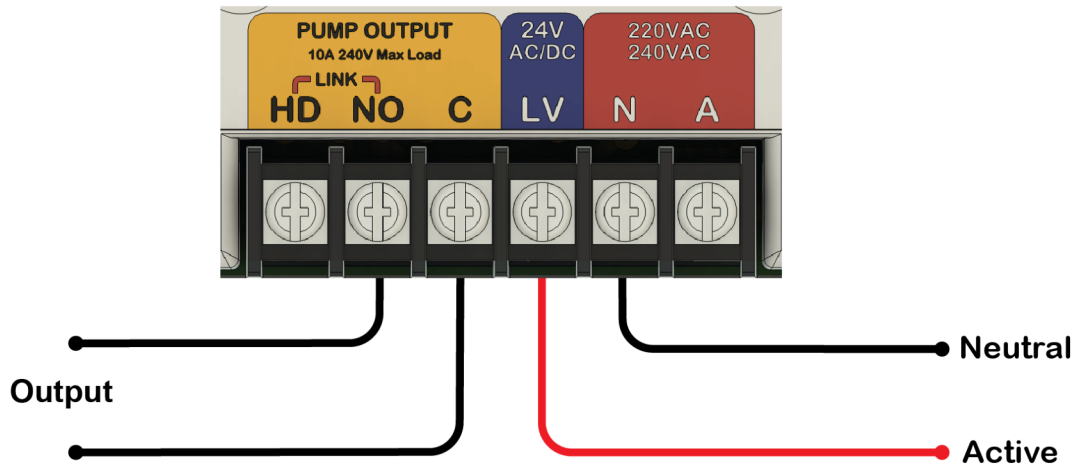

Output is a set of voltage free normally open contacts rated at 10 Amps (Resistive) at 240VAC

Basic three phase pump control

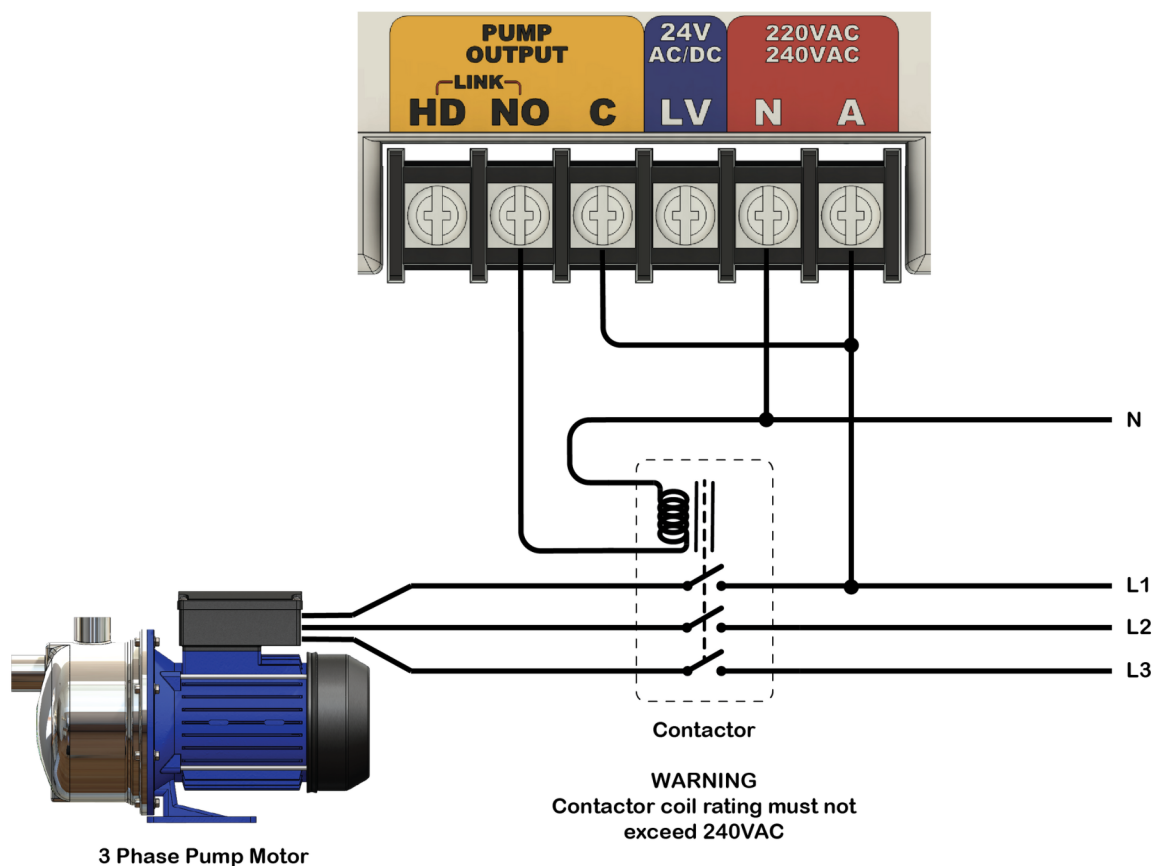

Basic single phase pressure system

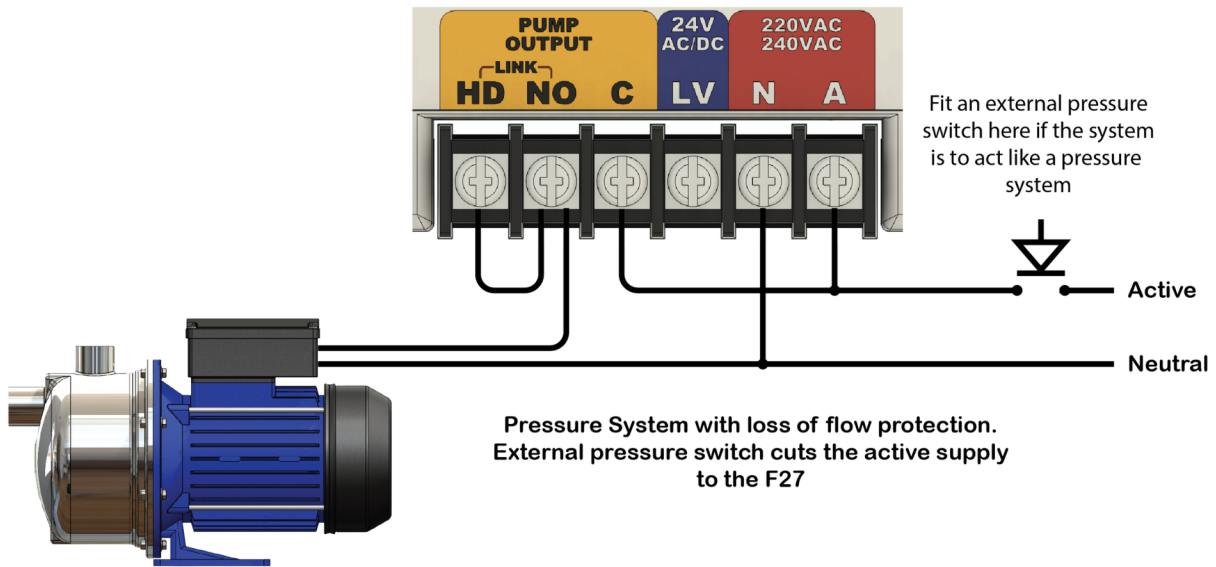

Basic pressure system suggested configuration

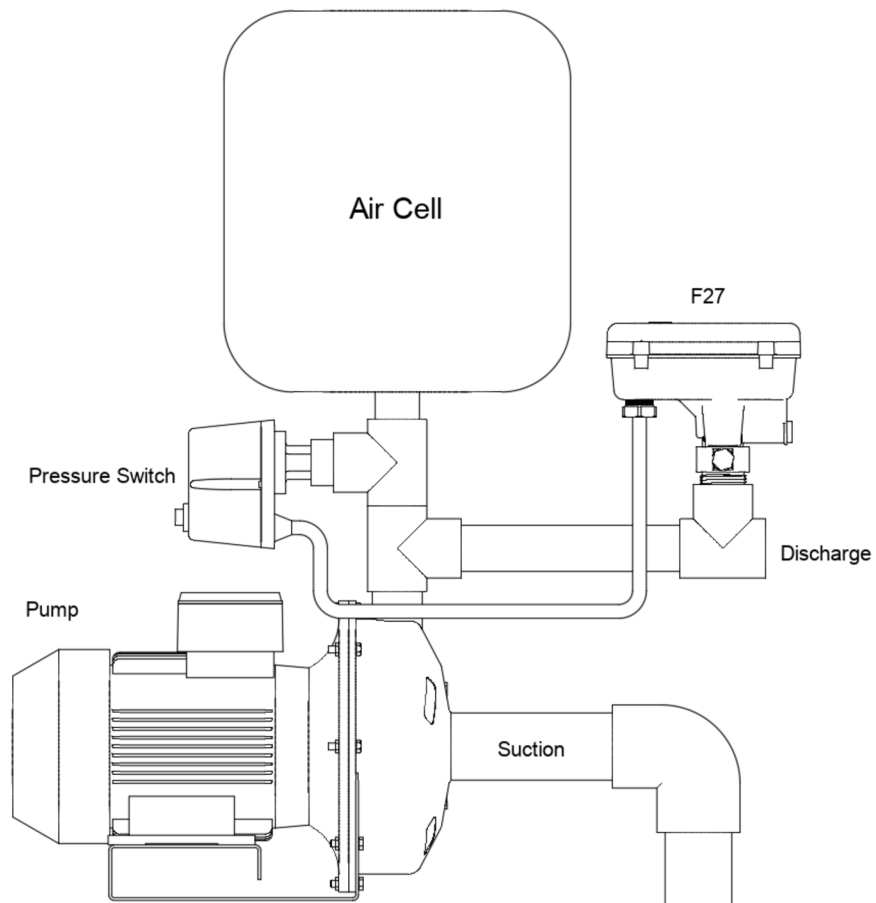

Maximum motor size 10A at 240V (P1) 2.4kw

HD TERMINAL

The F27 contains a solid-state switch marked HD (Heavy Duty) on the F27 terminal block. The HD solid-state switch can be used to protect the contacts of the F27 output relay by eliminating the destructive arcing caused by the starting and stopping of motors. The solid state switch is accessible from the F27 terminal block. To implement the HD function simply connect a heavy (>1mm sq) link wire between the HD and the NO terminals on the F27 terminal block. We recommend the HD drive be used whenever the F27 is used to directly control a single phase motor. The HD drive should not be used when the F27 is connected to a contactor, external timer, low wattage relay or to any other external device where voltage-free contacts are required. It is strictly intended for the direct control of highly inductive AC motor loads. The HD terminal and the F27's built in relay must never be connected to a DC motor or any DC load under any circumstances.

TIMER LED

The timer LED indicates when the start timer or run-on timer are running by flashing blue. Provided the timer dials are set to some value other than zero, this LED indicates that the start timer is running by blinking blue once per second. It also indicates when the run-on timer is running by flashing rapidly blue. The pump will be running whenever the blue timer LED is flashing.

PUMP LED

The pump LED turns green when a pump connected to the F27 is running. This LED turns red whenever the F27 output relay is off and the pump connected to it has stopped.

DIALS

The F27 has two 16 position rotary switches on its top deck that allow suitable start and run-on time delays to be selected. The dials are marked Start Timer and Run-On Timer. The two timers act independently of each other. For example, it is possible to set a start time on the start timer dial but leave the run-on timer set to zero. Doing so would result in the F27 starting the pump when power was switched on. However, in the event of subsequent loss of flow, the pump would instantly stop rather than run-on for a set period. When selecting a suitable time delay by rotating the dials please note that the changes you make do not take effect until the power to the F27 is reset (turned off and back on).

Kelco Engineering Pty Ltd

ABN 20 002 834 844

Head Office & Factory: 9/9 Powells Road, Brookvale 2100 NSW Australia

Postal Address PO Box 7485 Warringah Mall Brookvale 2100 NSW Australia

Phone: +61 2 99056425

Fax: +61 2 9905 6420

Email: Sales@kelco.com.au

Web: www.Kelco.com.au

All rights reserved copyright Kelco Engineering Pty Ltd © 2025

PLEASE NOTE: Kelco Engineering Pty Ltd reserves the right to change the specification of this product without notice. Users will use their own judgment to determine the appropriateness of using Kelco Products in an application, any safety measures required and that the product is properly installed for that application . To the extent permitted by law Kelco Engineering Pty Ltd disclaims and excludes all and any liability for the use of this product in any particular application or for defective installation. Kelco switches are warranted against malfunction by a 12 month return to base manufacturer's warranty. Full details of our warranty and limitation of liability can be found in this document or downloaded from: <http://www.kelco.com.au/warranty>